

(, , ,)

, .

, ,

, .

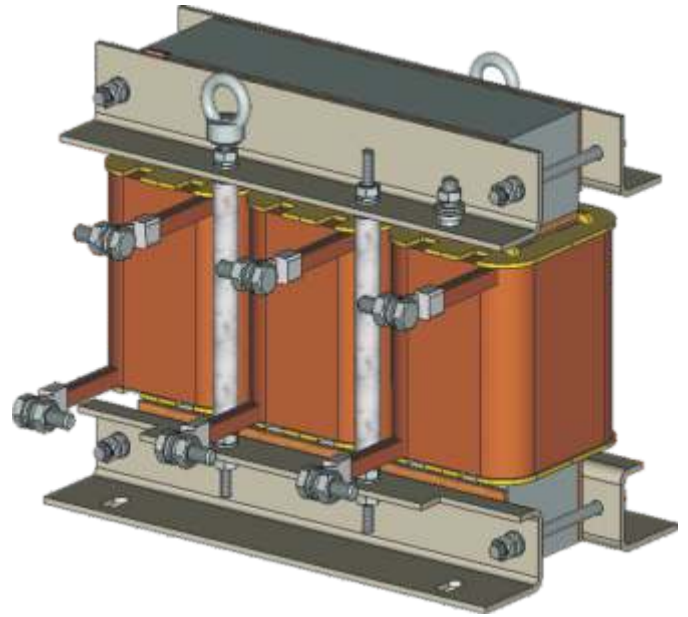
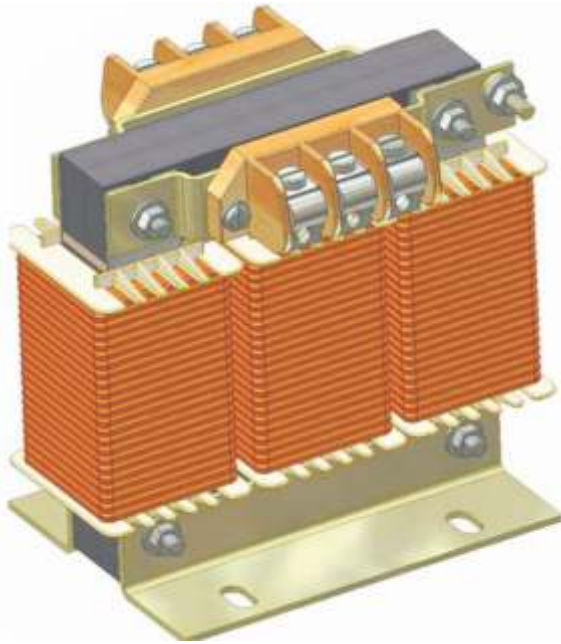

BY 100211261.053-2007.

-50 .

- 660 .

- 3 15150-69,
ta 25° .

- 30631-99

1

-

- 8865-93.

I 12.2.007.0-75

IP00

14254-96.

		-	-	* -	* -	* -
-10-2,20 3	0,16	10	2,20	0,07764	6,91	25,6
C-10-3,00 3		10	3,00	0,08005	9,42	26,4
-10-4,00 3		10	4,00	0,07960	12,57	26,3
-15-1,42 3		15	1,42	0,03483	6,69	25,9
-16-1,91 3	0,25	16	1,91	0,02654	9,60	22,4
-20-1,06 3		20	1,06	0,01658	6,66	21,8
-30-0,70 3	0,4	30	0,70	0,01018	6,6	30,2
-32-0,60 3		32	0,60	0,00917	6,03	31
-40-0,50 3		40	0,50	0,00550	6,28	29
-40-0,53 3		40	0,53	0,00572	6,66	30,2
-36-1,00 3	0,63	36	1,00	0,00767	11,31	32,8
-48-0,40 3		48	0,40	0,00395	6,03	30,1
-50-0,42 3		50	0,42	0,00363	6,60	29,9
-60-0,36 3		60	0,36	0,00274	6,79	32,6
-75-0,18 3		75	0,18	0,00162	4,24	30
-63-0,47 3	1,0	63	0,47	0,00268	9,30	35,1
-80-0,26 3		80	0,26	0,00151	6,53	32,1
-170-0,12 3	1,6	170	0,12	0,000659	6,41	62,9
-80-0,5 3		80	0,5	0,00315	12,57	66,6
C-235-0,09 3	2,5	235	0,09	0,000413	6,64	75,2
-350-0,04 3		350	0,04	0,000187	4,40	75,3
-250-0,13 3	4,0	250	0,13	0,000449	10,21	92,6
1	±10 %;					
2	±10 %;					
*	25? .					

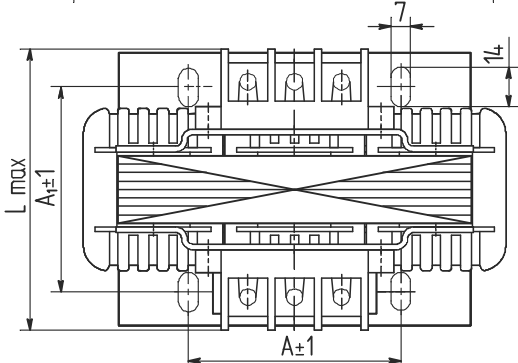
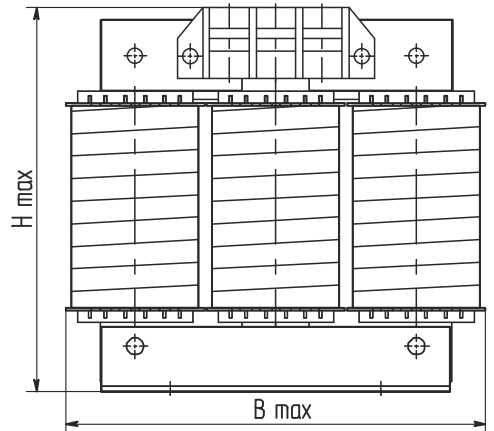

Puc. 1

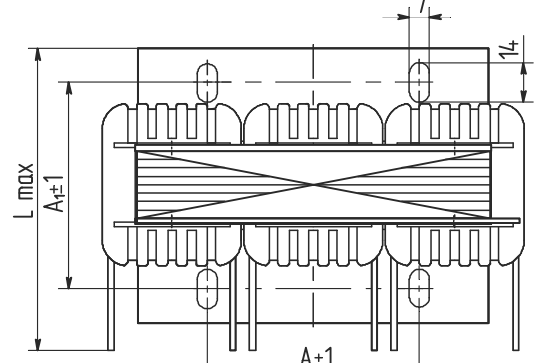
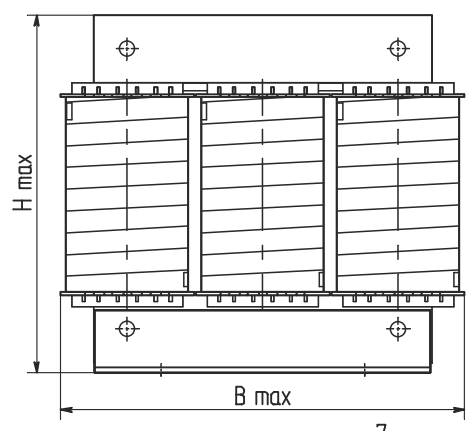

Puc. 2

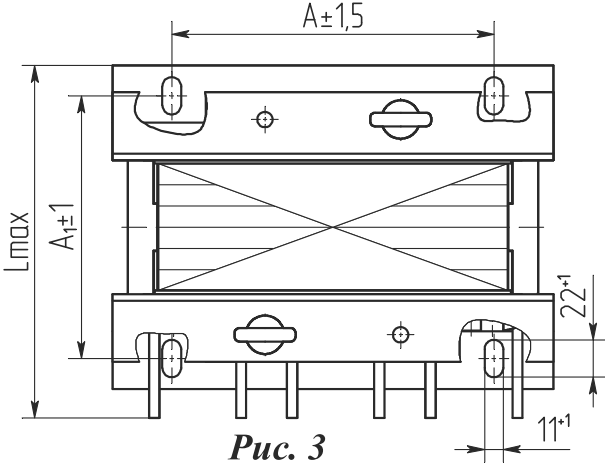
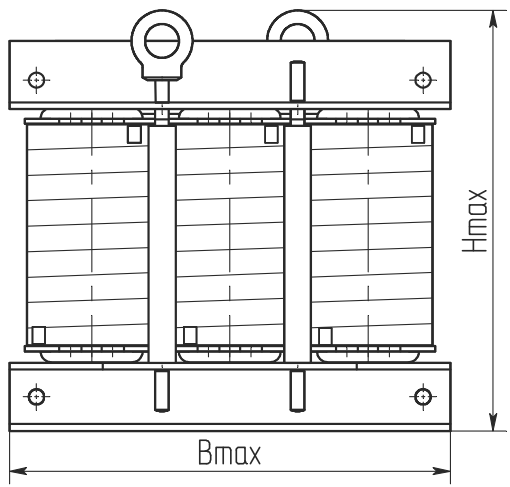

Puc. 3

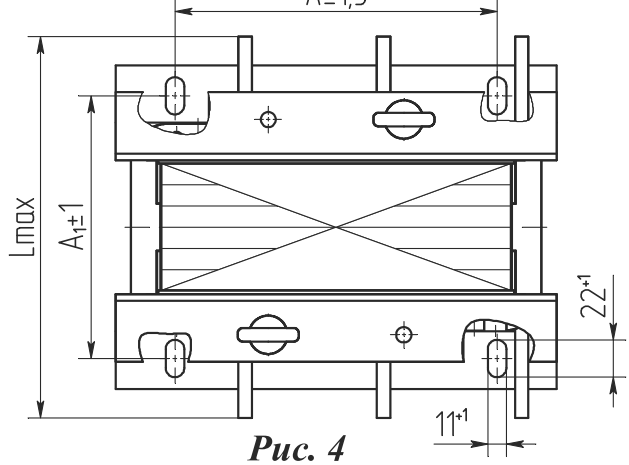
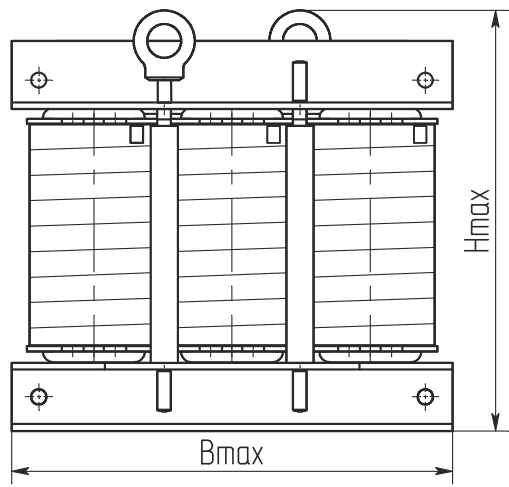

Puc. 4

Размеры в миллиметрах

	·		1	Bmax	Lmax	Hmax	,
-10-2,20	3	1	62	152	92	140	2,30
C-10-3,00	3						2,73
-10-4,00	3						3,47
-15-1,42	3						2,95
-16-1,91	3						4,15
-20-1,06	3		3,75				
-30-0,70	3		88		117		5,20
-32-0,60	3						5,19
-40-0,50	3						5,96
-40-0,53	3						6,02
-36-1,00	3						8,93
-48-0,40	3	2	88	178	184	7,56	
-50-0,42	3					8,13	
-60-0,36	3					9,32	
-75-0,18	3		7,91				
-63-0,47	3		104		203	11,95	
-80-0,26	3					11,75	
-170-0,12	3		3		127	262	226
-80-0,5	3	190		265			
C-235-0,09	3				155		245
-350-0,04	3			362			33,5
-250-0,13	3	250		149	332		237

170 , 0,12
 :
 -170-0,12 3 Y 100211261.053-2007.